

# WAF102.50A

Lavoce

## 10" WOOFER

FERRITE MAGNET  
ALUMINIUM BASKET DRIVER



- 2.5 INCH CCAR VOICECOIL
- 98,5 dB/SPL SENSITIVITY
- 500 WATT PROGRAM POWER HANDLING
- FEM OPTIMIZED FERRITE MOTOR AND SUSPENSIONS
- OPTIMIZED COOLING SYSTEM
- RESONANCE FREE AND HEAVY DUTY BASKET DESIGN

### GENERAL SPECIFICATIONS

Nominal diameter	mm (in.)	250 (10)
Nominal impedance	$\Omega$	8
Minimum impedance	$\Omega$	6,5
Program power (1)	W	500
AES Power rating (2)	W	250
Sensitivity (3)	dB	98,5
Frequency range	Hz	70 ÷ 4500
Voice coil diameter	mm (in.)	65 (2.5)
Chassis material	Aluminium	
Magnet material	Ferrite	
Magnet dimensions OD x ID x h	mm (in.)	155 x 80 x 20 (6.1 x 3.1 x 0.8)
Coil material	CCAR	
Former material	Glass Fiber	
Cone material	Water Proof Treated Paper	
Surround material	Polycotton	
Xmax (4)	mm (in.)	5 (0.19)
Xmech (5)	mm (in.)	9 (0.35)
Gap height	mm (in.)	8 (0.3)
Voice coil winding height	mm (in.)	14 (0.55)

### SMALL SIGNAL PARAMETERS

DC resistance	Re	Ohm	5,5
Resonance frequency	Fs	Hz	71
Moving mass	Mms	g (oz)	36 (1.27)
Compliance	Cms	mm/N	0,14
Force factor	BxL	N/A	15,6
Mechanical Q-factor	Qms		4,23
Electrical Q-factor	Qes		0,36
Total Q-factor	Qts		0,33
Equivalent air volume	Vas	l (ft <sup>3</sup> )	29 (1)
Voice coil Inductance	Le	mH	0,8
Diaphragm area	Sd	cm <sup>2</sup> (in. <sup>2</sup> )	380 (58.9)
Reference efficiency	Eta 0	%	2,75

### SHIPPING INFORMATION

Net weight	Kg (lb.)	4,6 (10)
Multipack size (2)	mm x mm x mm ( in. x in. x in.)	310 x 290 x 270 (12.2 x 11.4 x 10.6)
Multipack weight	Kg (lb.)	9,7 (21.4)

### FREQUENCY RESPONCE

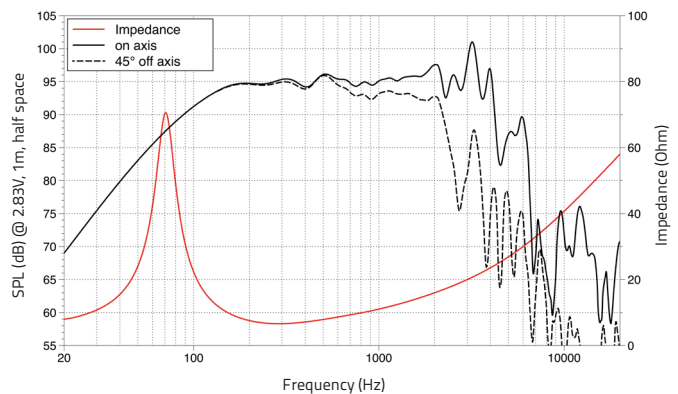

### DIMENSIONS mm (in.)

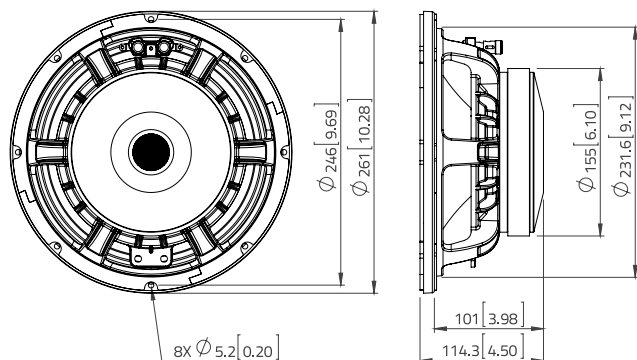

(1) Program power is defined as 3 dB greater than AES Power. (2) Tested for two hours using a continuous, band-limited pink noise signal as per AES 2-1984 Rev. 2003. Loudspeaker tested in free air. (3) From T/S parameters, measured with Klippel DA LPM module. (4) The Xmax is calculated as:  $(Hvc - Hg)/2 + Hg/4$ . Hvc is the voice coil height and Hg the gap height. (5) The Xmech is calculated as:  $(Hvc - Hg)/2 + (Hg - 2)$ . Hvc is the voice coil height and Hg the gap height. (6) Thiele-Small parameters are measured after preconditioning: a) at 20°C - 22°C, 50% humidity for 2 hours; b) by Klippel LSI measurement.

